

HEADLIGHT VISOR INSTALLATION

Some folks have had difficulties installing Big Bike 7" Headlight Visors (P/N 53429) after purchasing from Meancycles. A link to this part can be seen at:

<http://www.meancycles.com/Home.asp?PartID=182179&AccCategoryID=2341&AccCategoryTypeID=0&BikeModelID=5729&ManufacturerID=0&BikeType=Cruiser&CompanyID=0>

This is actually a fairly simple installation, as detailed below, but there's one little "trick" that's necessary to avoid problems.

Here's an exploded parts diagram of how things are to be disassembled:

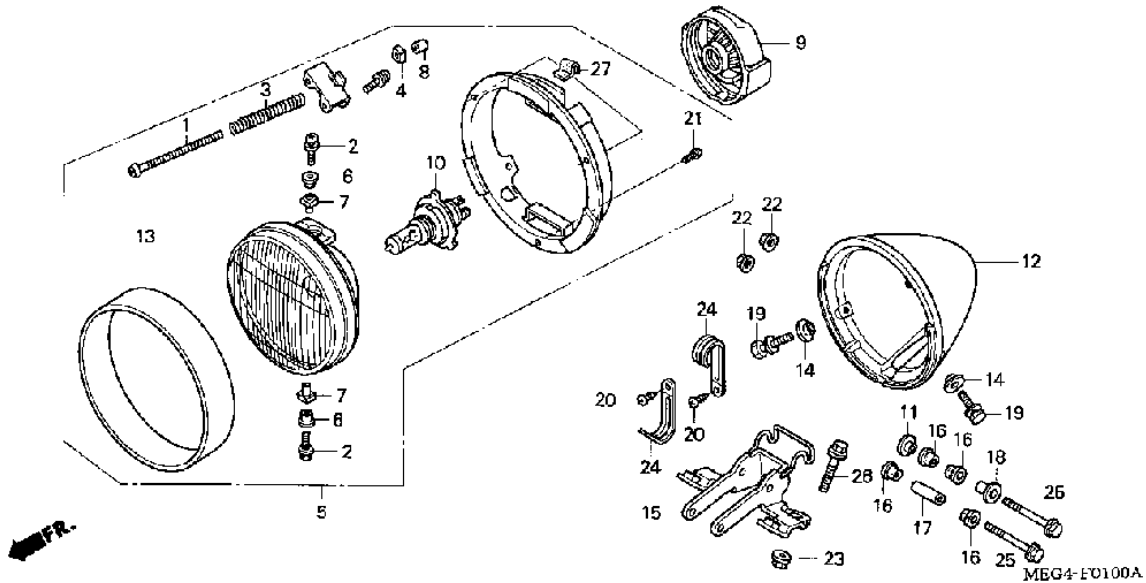

(continued next page)

The first step is to remove the two 8mm bolts (Item #19) which secure the Headlight Unit (Bubble #5) to the Headlight Case (Item #12):



Here's a closeup of the Bolt (Item #19) showing the Sleeve (Item #14), and take care not to lose the sleeve (don't ask me how I know...):



Open the “can”, so that the Headlight Unit (Bubble #5) is released from the Headlight Case (Item #12). In this view you can see the three Phillips Screws (Item #21) at the 4, 8 and 12 o'clock positions, and I have a screwdriver on the one that's located at 8 o'clock. These three screws attach the Headlight Rim (Item #13) to the Headlight Unit (Bubble #5)

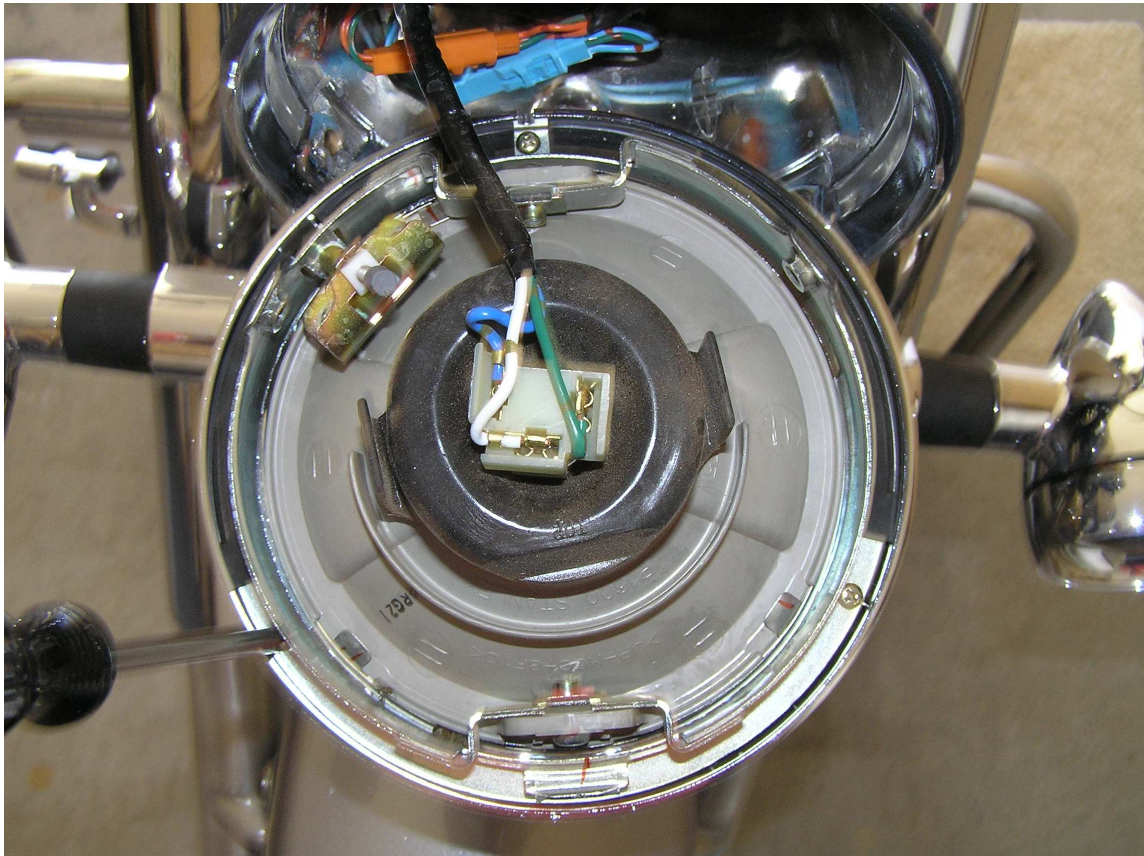

For reasons I don't understand, there are two hook-like tabs at the top of the visor. These are totally useless for our Aero bikes, and need to be modified or removed before proceeding further (and I think those two little tabs are what has been causing all the confusion of how to install the visor).

First grab a pair of pliers and straighten the tabs:



Then you can snip off the tab, or just leave it straightened out, no harm done either way. I chose to snip them off:



Here's a shot of the visor with the tabs removed:



Then install the visor from the REAR of the Headlight Rim (Item #13), and note the orientation in relation to the rim mounting screwholes:



Then just reassemble by reversing the above steps, it couldn't be simpler!

Here's a pic of the finished product:



Well, I hope that helped, and don't hesitate to contact me if any questions arise.

Regards,

Doc Weston
aka "Geezy Rider" on the forum

email: CaptainDoc@rockisland.com